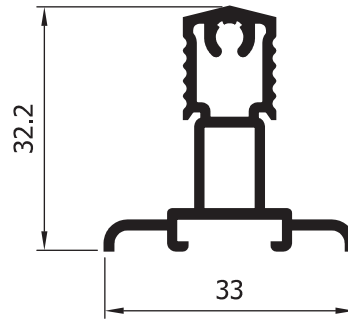
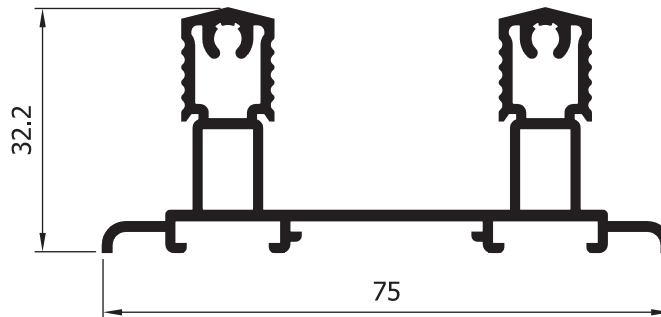

E-19110

392 g/m

**E-19111**

814 g/m

**E-19112**

1237 g/m

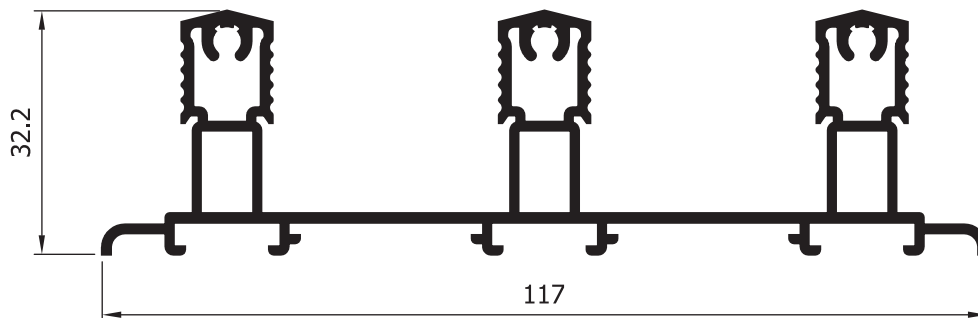

E-19100

540 g/m

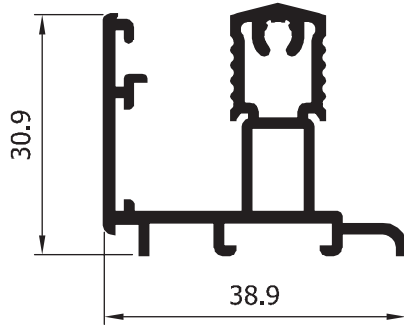
**E-19101**

963 g/m

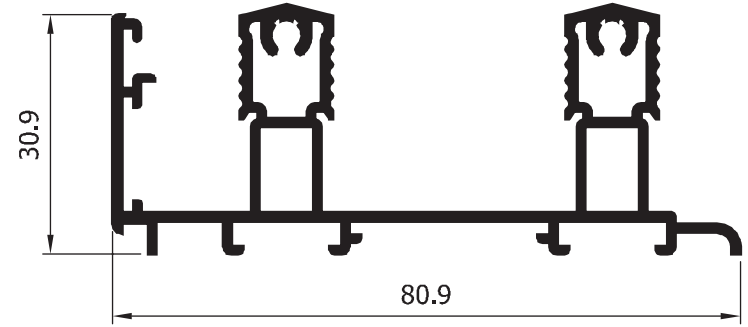
**E-19102**

1386 g/m

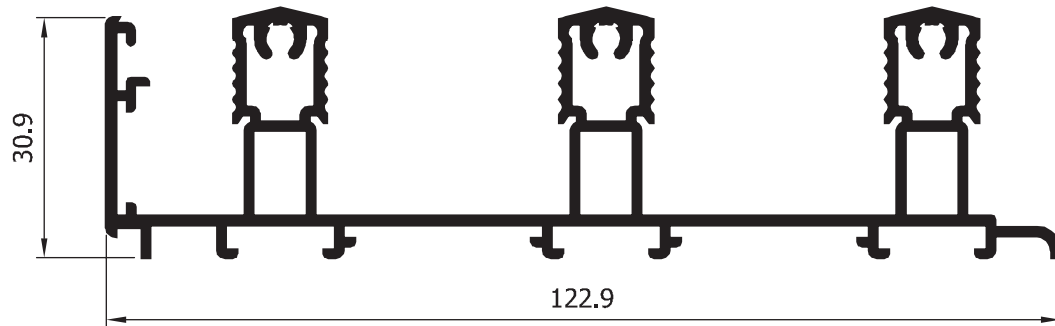
**E-19122**

1231 g/m

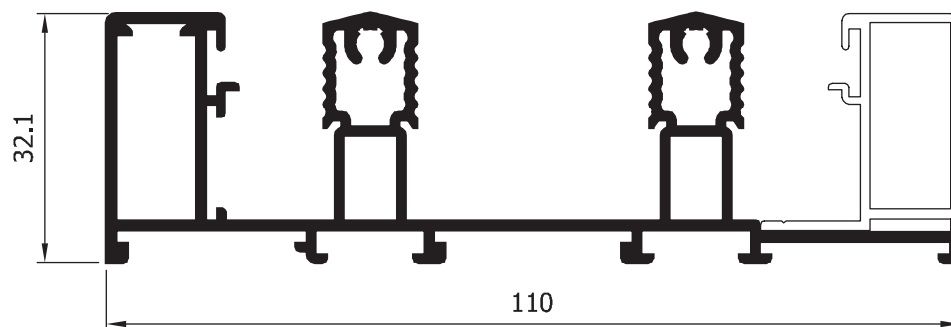

ΣΥΝΕΡΓΑΖΕΤΑΙ ΜΕ ΤΟ ΠΡΟΦΙΛ Ε-5340 ΤΗΣ ΣΕΙΡΑΣ Ε-2300
USED WITH PROFILE E-5340 OF E-2300 SERIES

E-19106

459 g/m

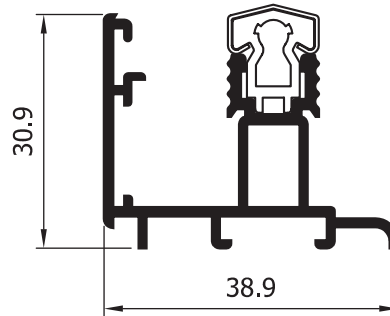

ΠΡΟΣΟΧΗ: ΣΤΟΝ ΚΩΔΙΚΟ E-19106 ΔΕΝ ΣΥΜΠΕΡΙΛΑΜΒΑΝΕΤΑΙ Ο ΑΝΟΞΕΙΔΩΤΟΣ ΟΔΗΓΟΣ E-19602
ATTENTION: THE PROFILE WITH CODE E-19106 DOES NOT INCLUDE STAINLESS STEEL RAIL E-19602

E-19107

804 g/m

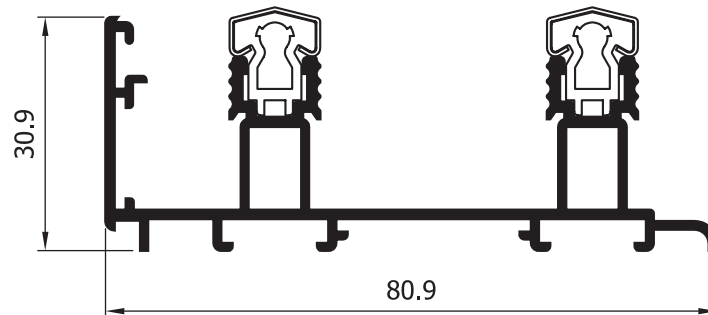

ΠΡΟΣΟΧΗ: ΣΤΟΝ ΚΩΔΙΚΟ E-19107 ΔΕΝ ΣΥΜΠΕΡΙΛΑΜΒΑΝΕΤΑΙ Ο ΑΝΟΞΕΙΔΩΤΟΣ ΟΔΗΓΟΣ E-19602
ATTENTION: THE PROFILE WITH CODE E-19107 DOES NOT INCLUDE STAINLESS STEEL RAIL E-19602

E-19108

1145 g/m

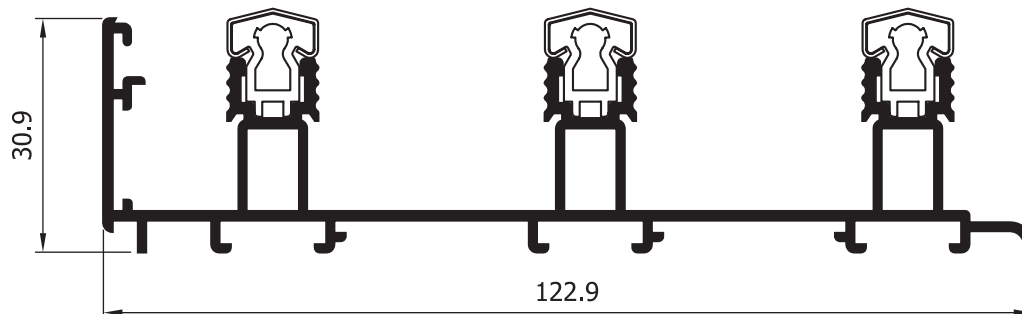

ΠΡΟΣΟΧΗ: ΣΤΟΝ ΚΩΔΙΚΟ E-19108 ΔΕΝ ΣΥΜΠΕΡΙΛΑΜΒΑΝΕΤΑΙ Ο ΑΝΟΞΕΙΔΩΤΟΣ ΟΔΗΓΟΣ E-19602
ATTENTION: THE PROFILE WITH CODE E-19108 DOES NOT INCLUDE STAINLESS STEEL RAIL E-19602

E-19103

689 g/m

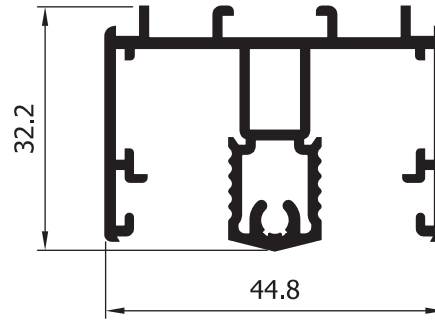

E-19104

1111 g/m

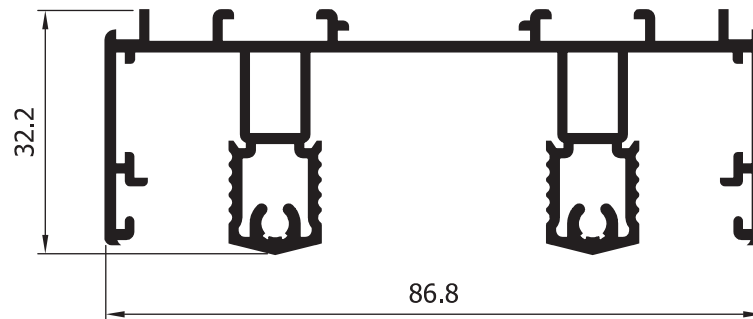

E-19105

1536 g/m

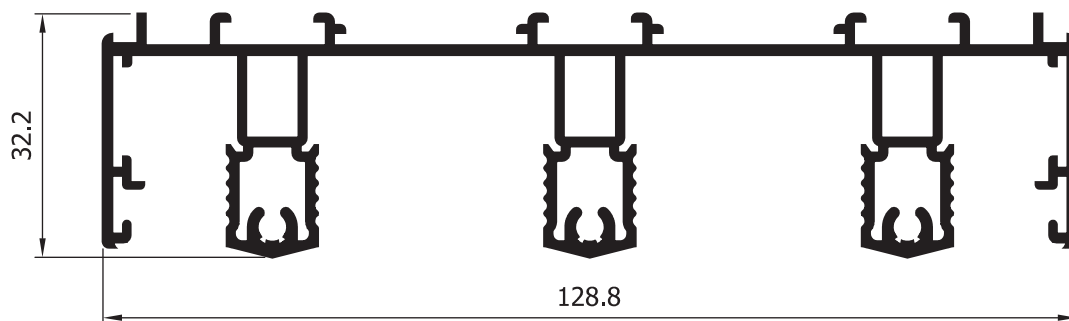

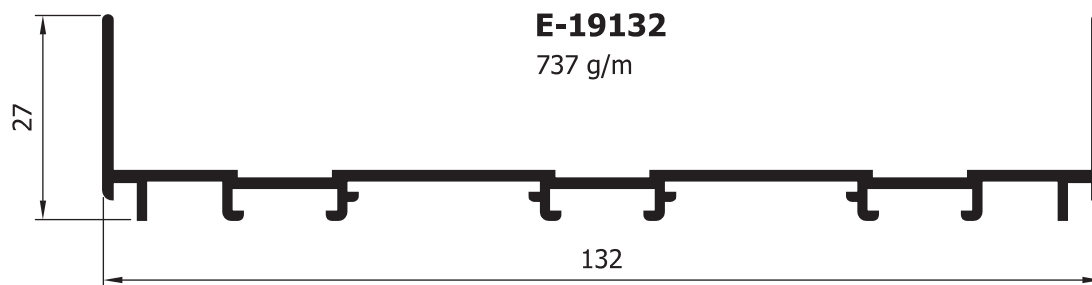
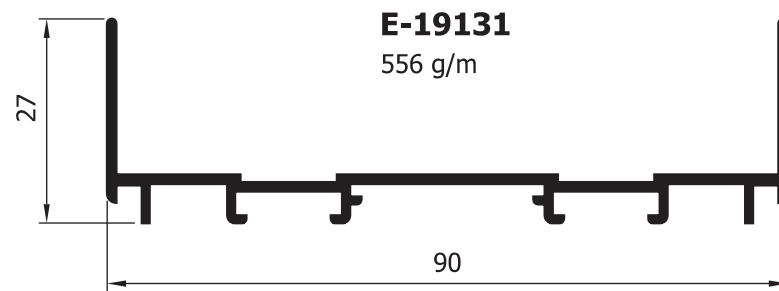
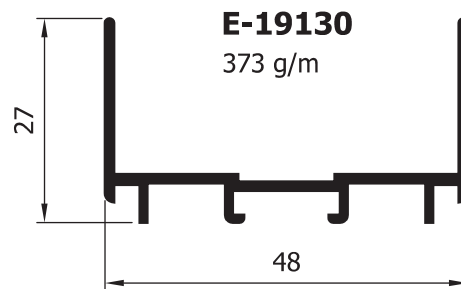

E-19120

975 g/m

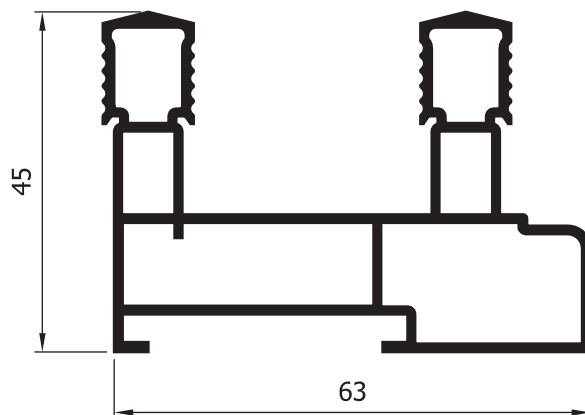

E-19121

847 g/m

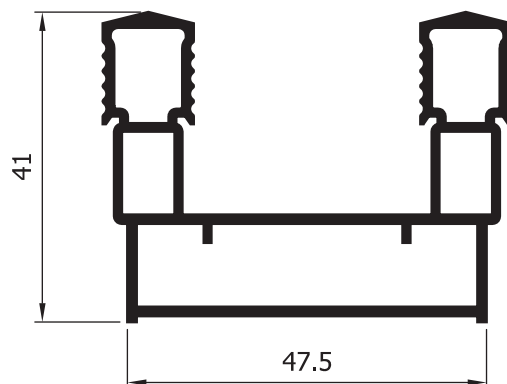

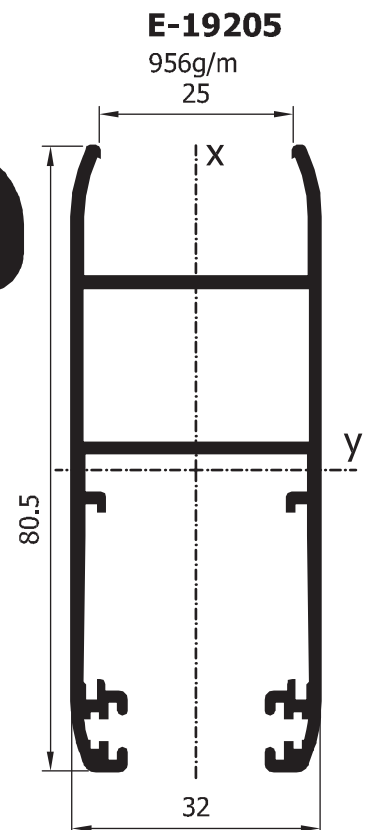
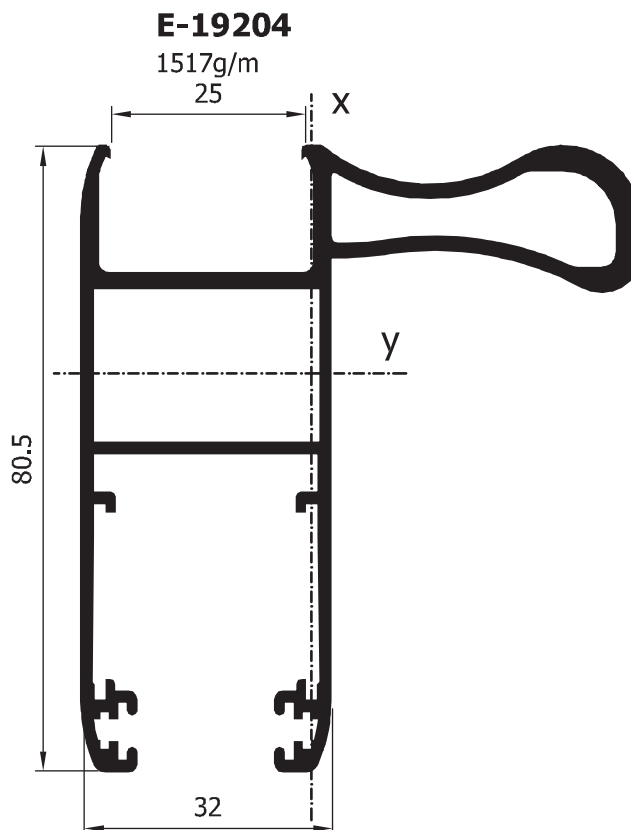
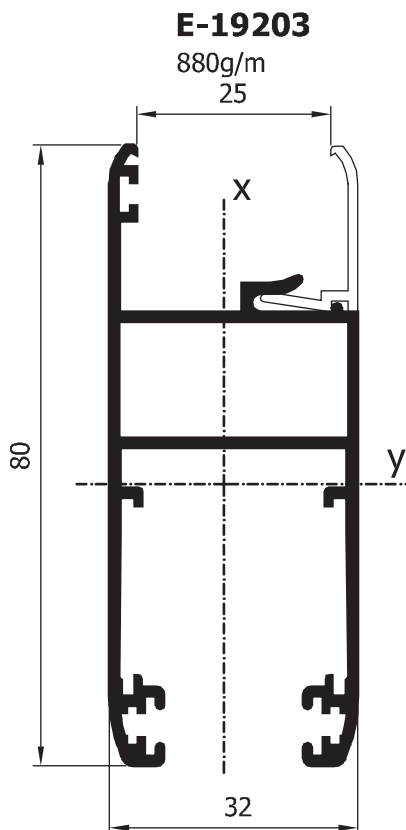
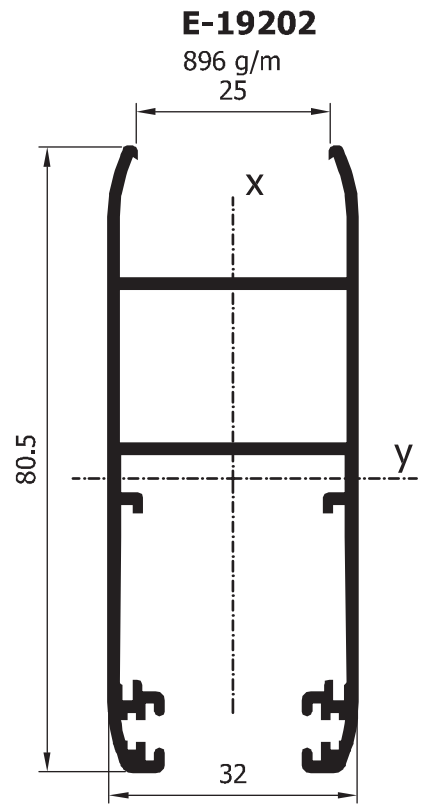
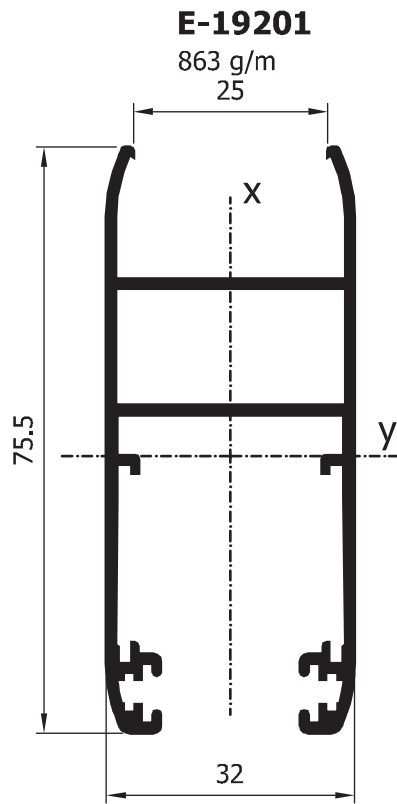
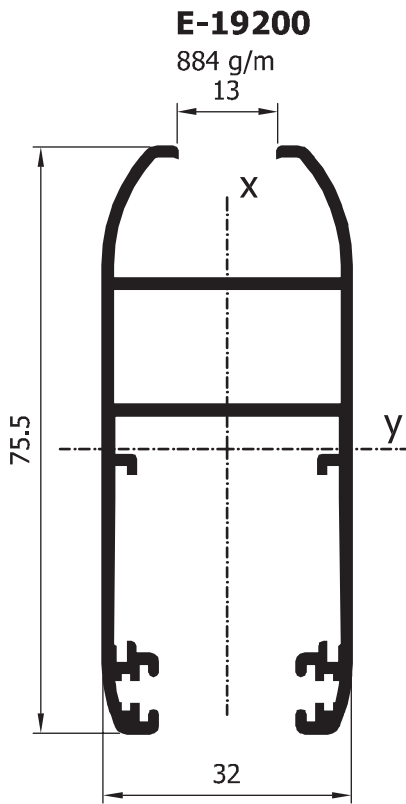

E-19630

122 g/m

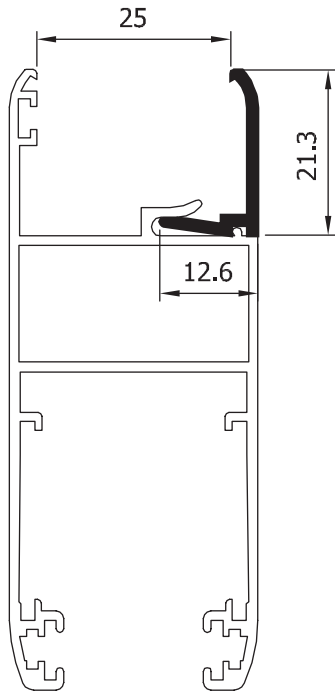
**E-19501**

370 g/m

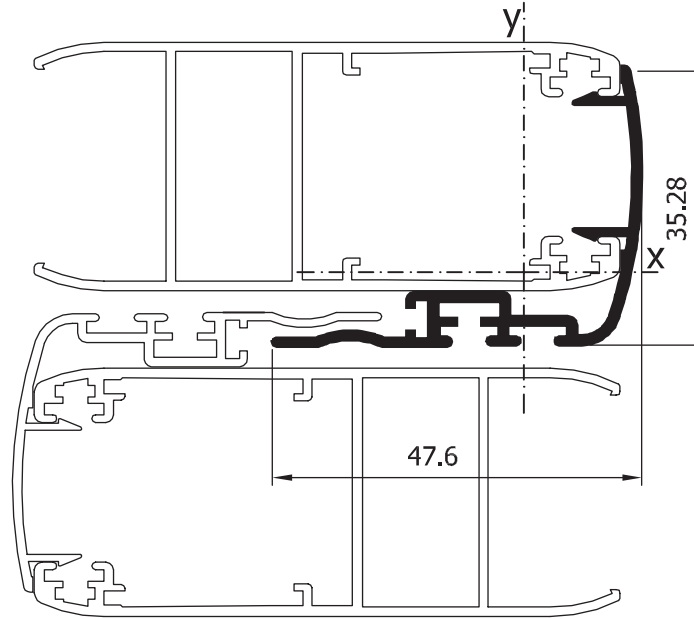
**E-1214**

857 g/m

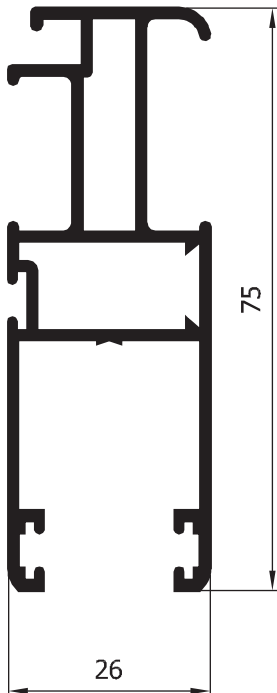
**E-19610**

191 g/m

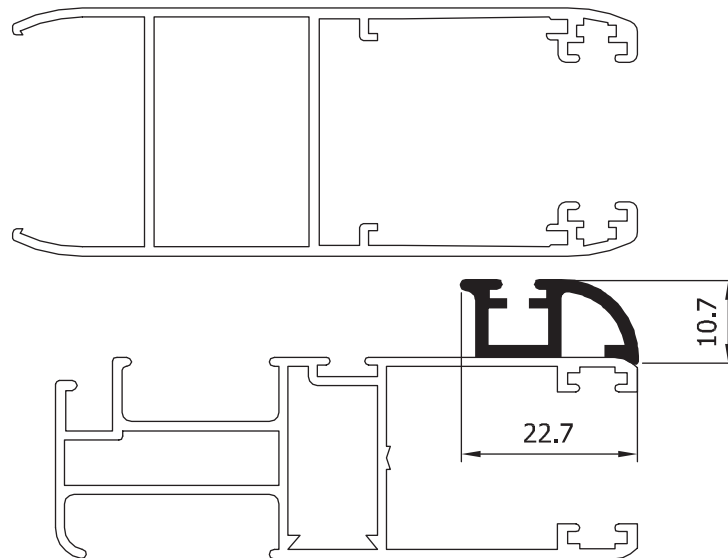

E-19510

673 g/m

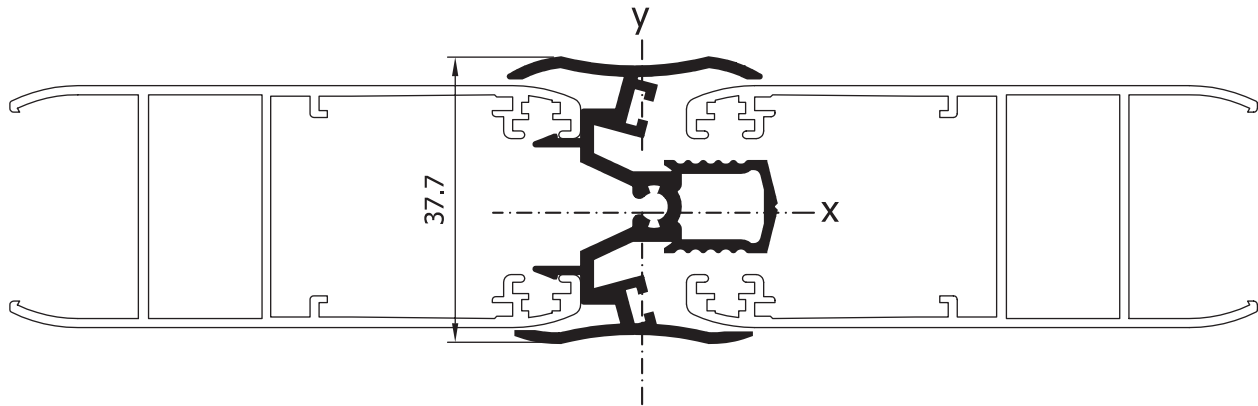
**E-19511**

310 g/m

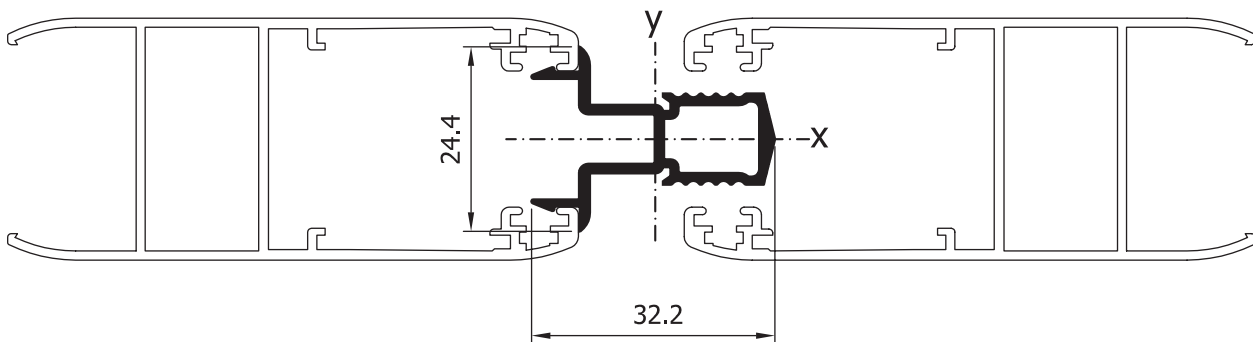
**E-19512**

284 g/m

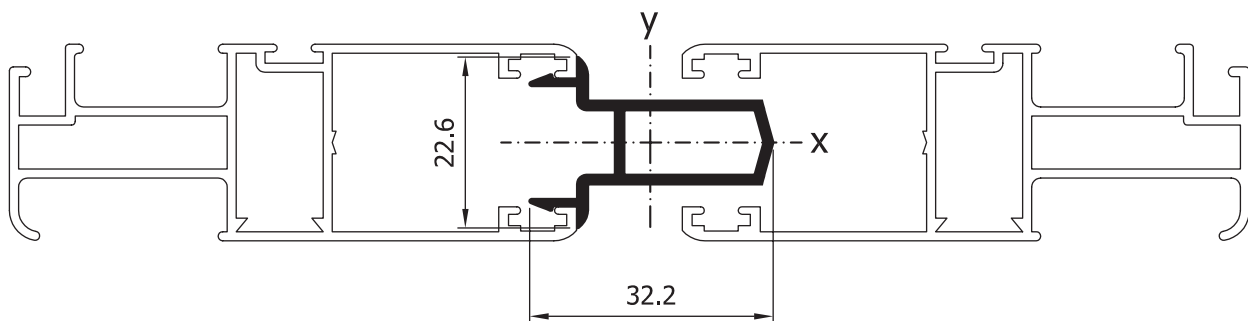

E-19300

575 g/m

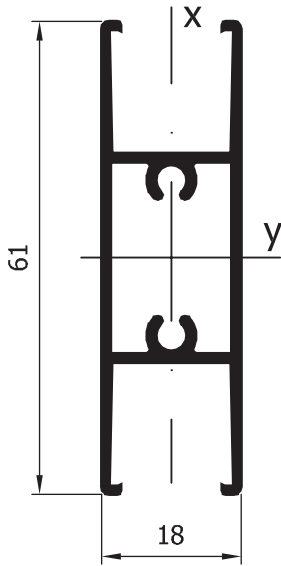

E-19301

602 g/m

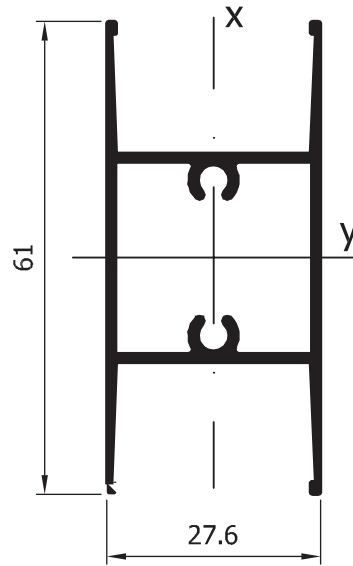

E-1210

590 g/m

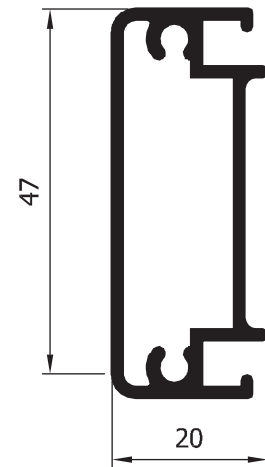

E-19643

186 g/m

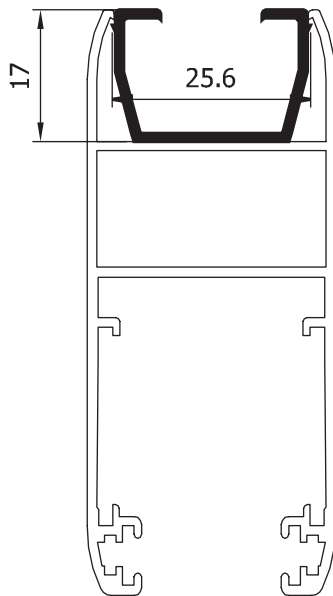

E-19650

103 g/m

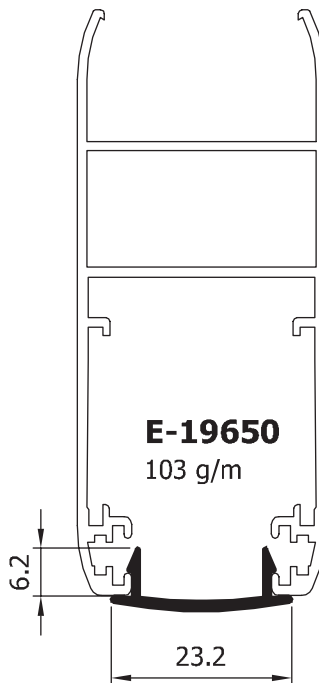

E-19651

100 g/m

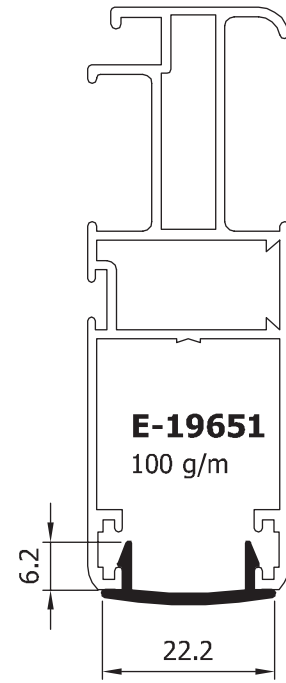

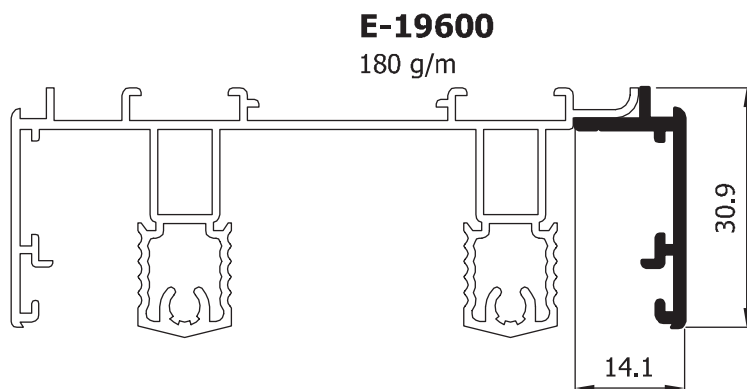
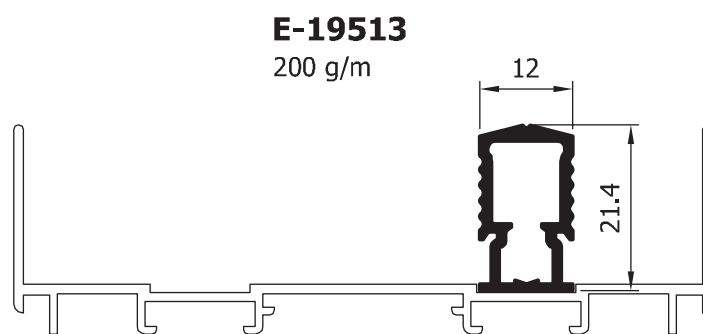
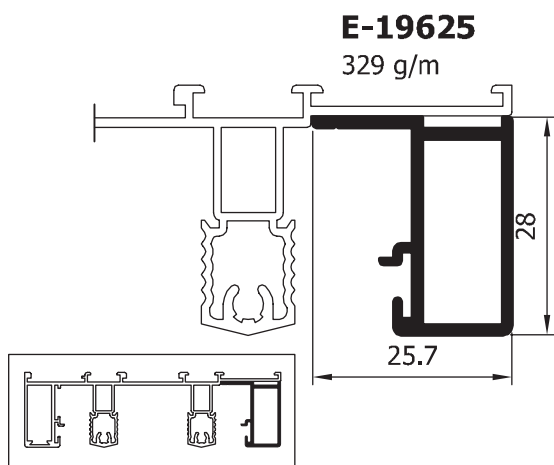
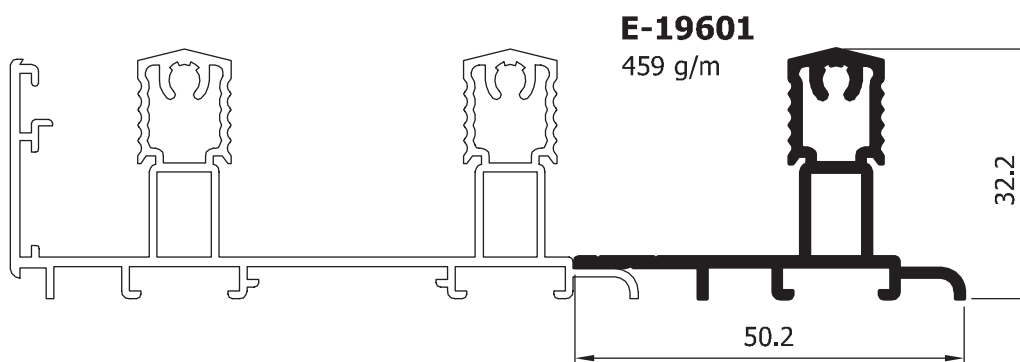
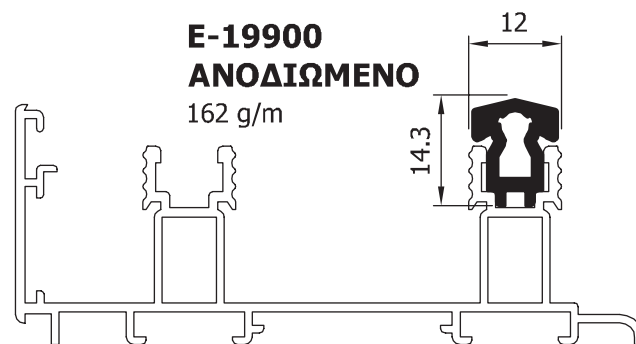
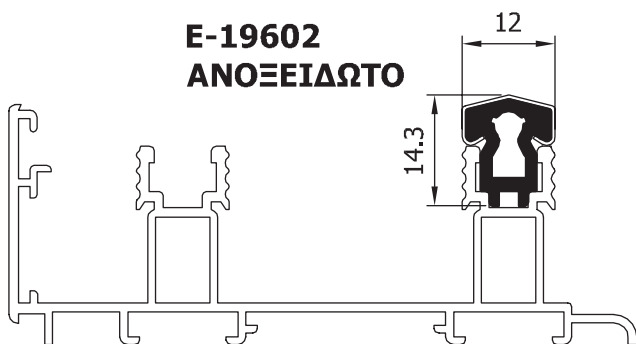



E-19622

205 g/m

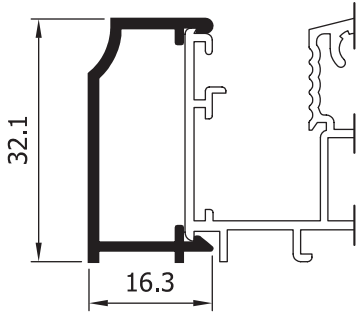

E-19620

194 g/m

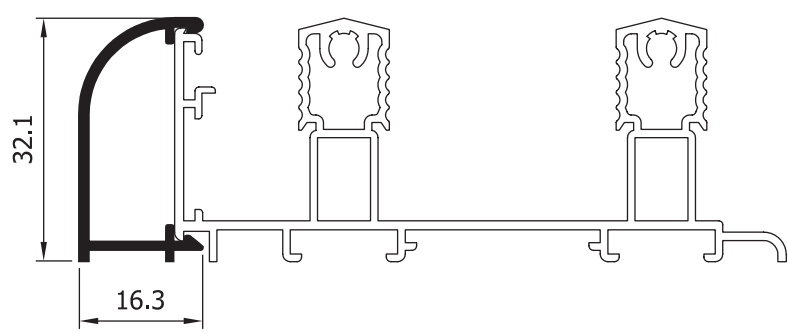

E-19621

343 g/m

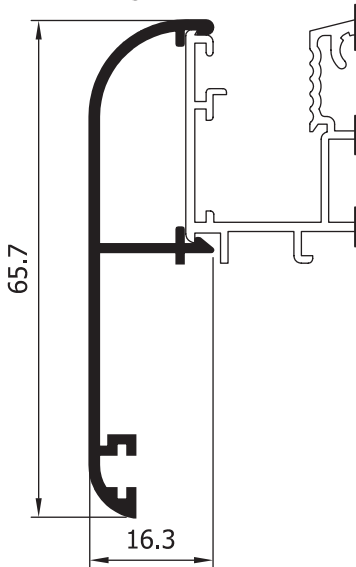

E-5366

269 g/m

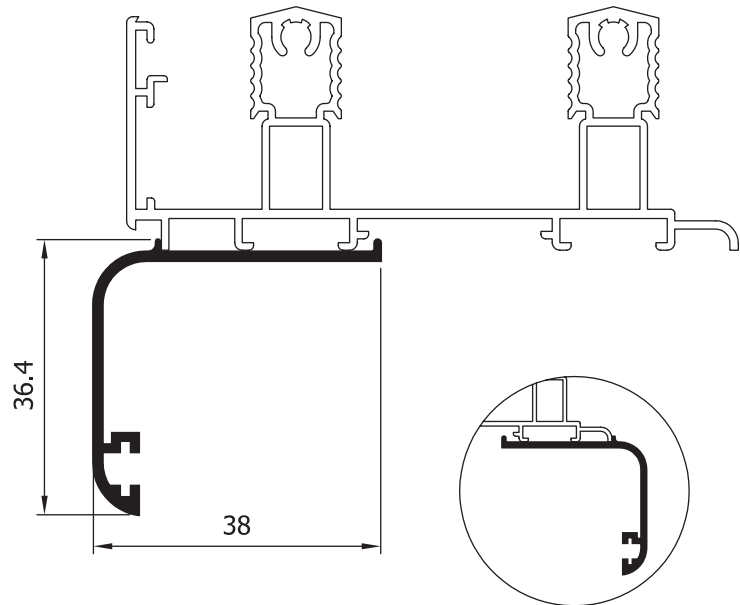

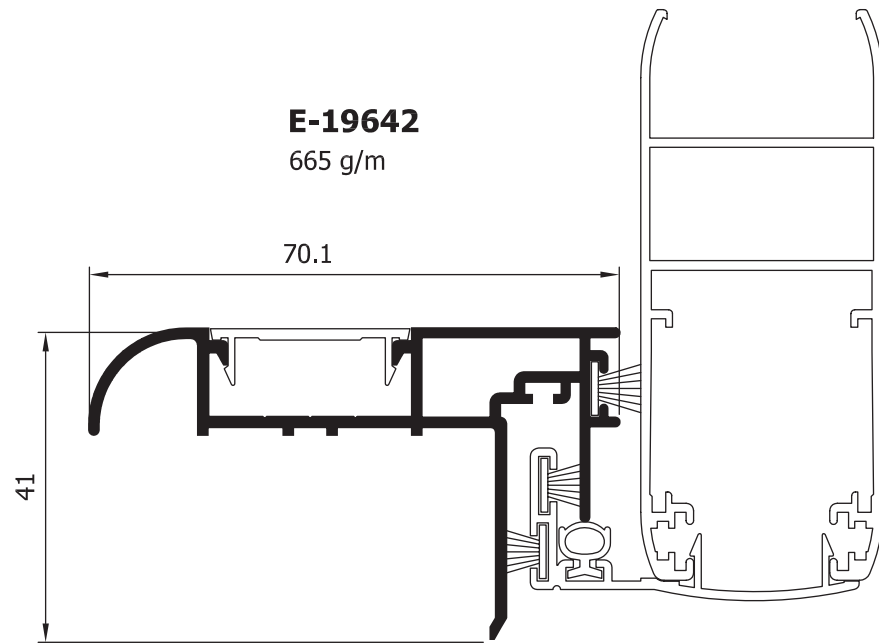
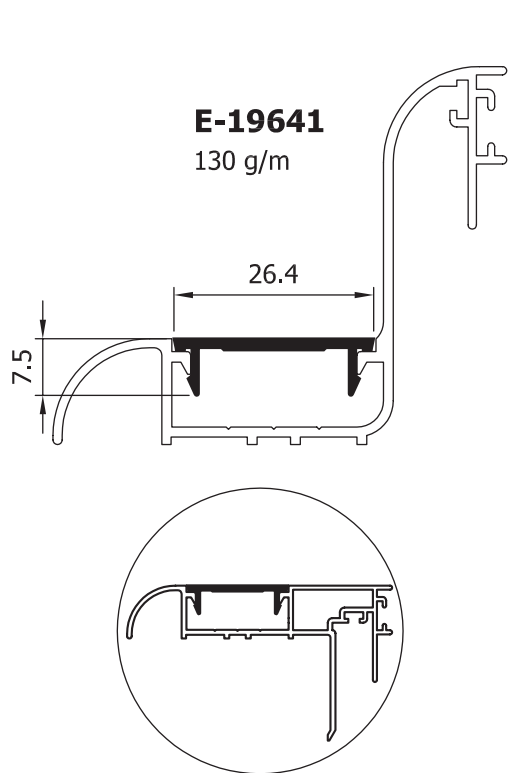
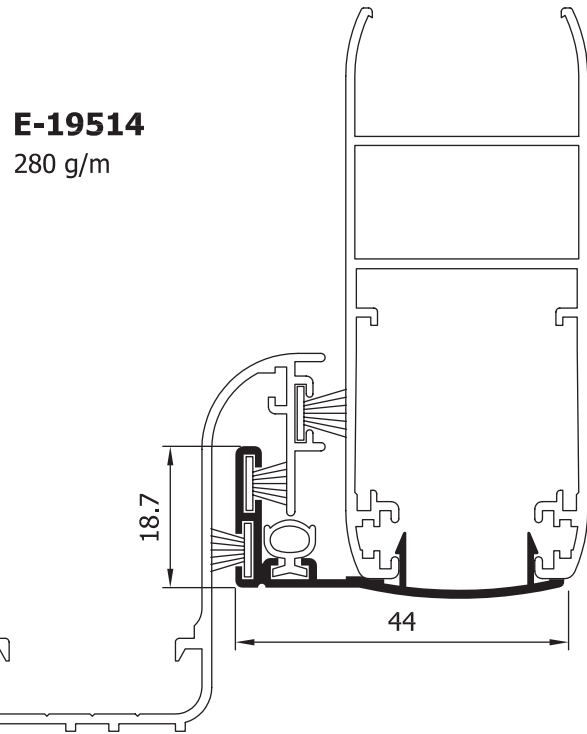
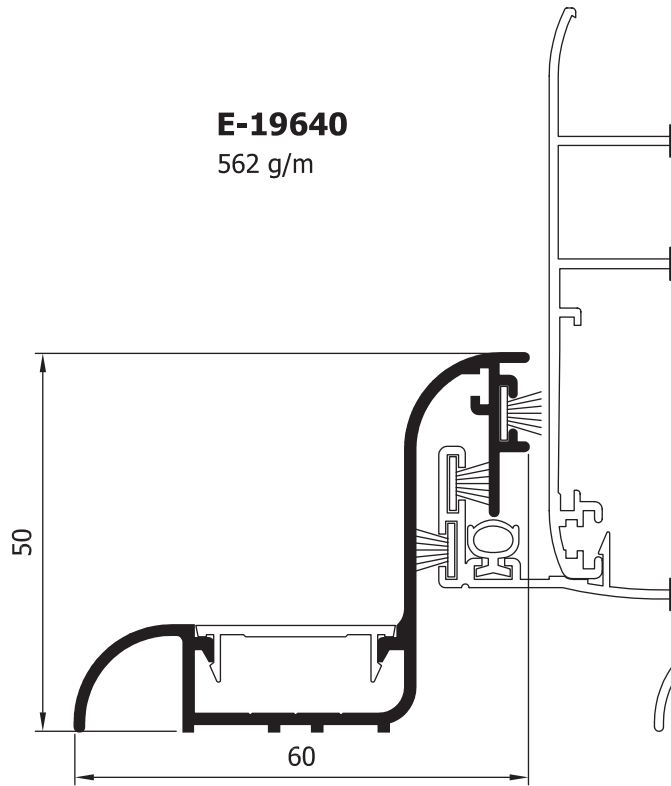

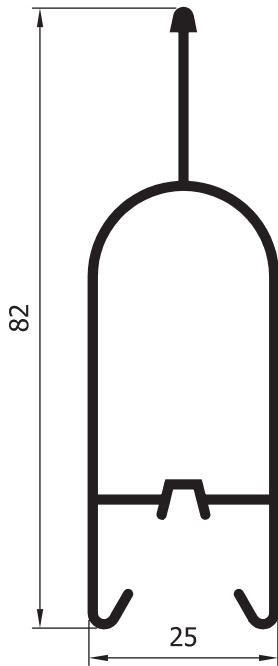
**P-1500**

540 g/m
8.50 Kgr/m²
16 τεμ/μ²

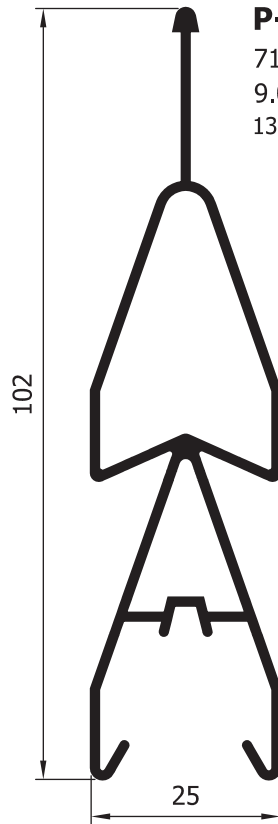
**P-1501**

718 g/m
9.09 Kgr/m²
13 τεμ/μ²

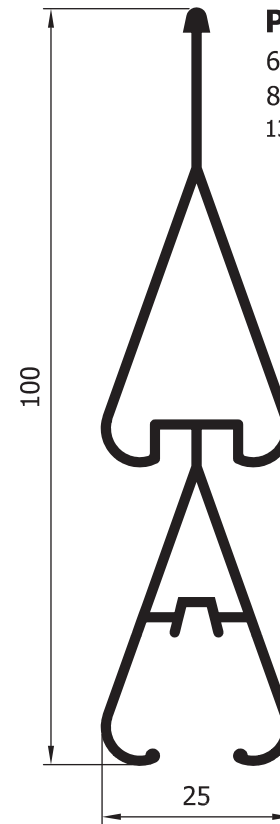
**P-1502**

686 g/m
8.68 Kgr/m²
13 τεμ/μ²

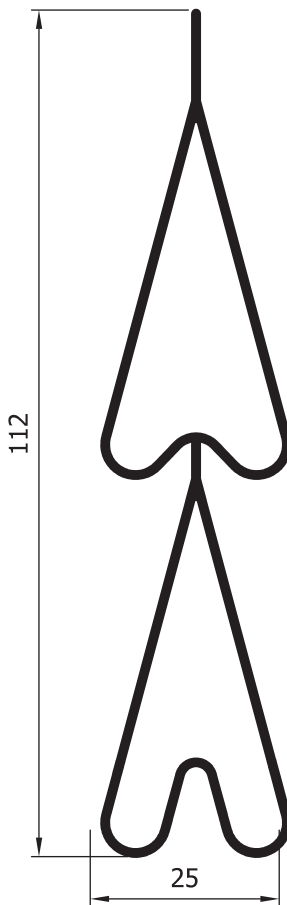
**P-1503**

718 g/m
7.18 Kgr/m²
10 τεμ/μ²

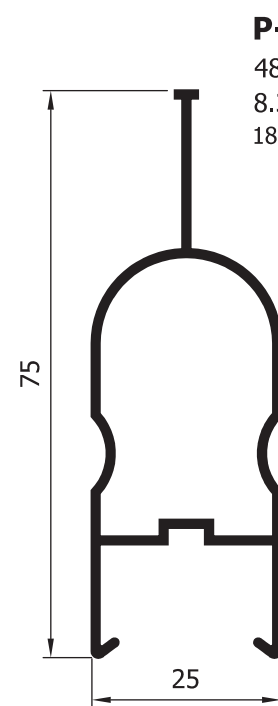
**P-1504**

482 g/m
8.34 Kgr/m²
18 τεμ/μ²

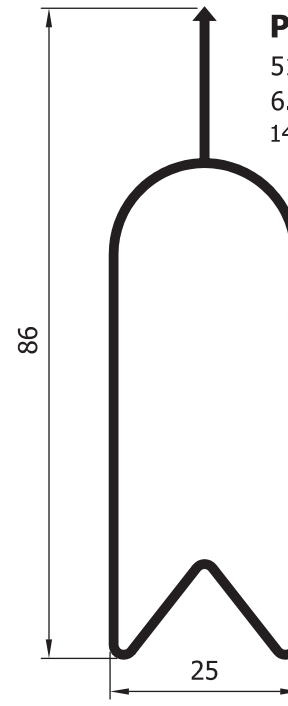
**P-1505**

510 g/m
6.89 Kgr/m²
14 τεμ/μ²

P-1596

943 g/m
7.86 Kgr/m²
9 τεμ/μ²

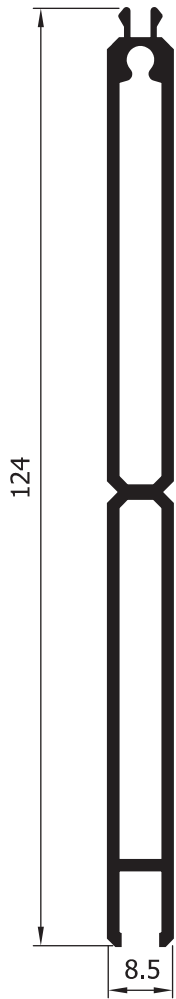
**P-1543**

982 g/m
9.85 Kgr/m²
10 τεμ/μ²

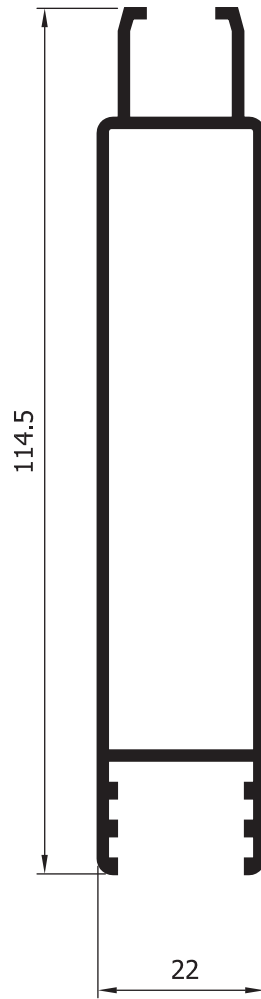
**P-1506**

305 g/m
4.73 Kgr/m²
16 τεμ/μ²

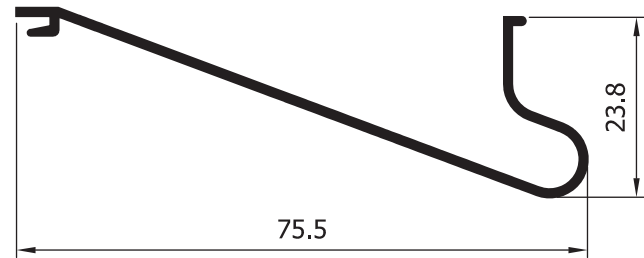
**P-1569**

321 g/m
8.02 Kgr/m²
25 τεμ/μ²

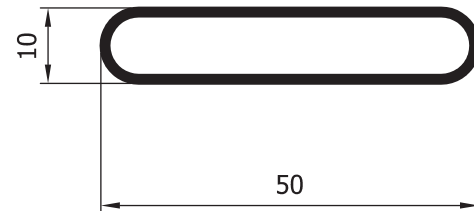
**P-1577**

335 g/m
4.01 Kgr/m²
13 τεμ/μ²

